

**Section 9—Plug-In Units—Bus Plugs**  
**Fusible Switch Plug-In Unit— 400 A (Type “PBQA”)**

**Fusible Switch Plug-In Unit— 400 A (Type “PBQA”)**

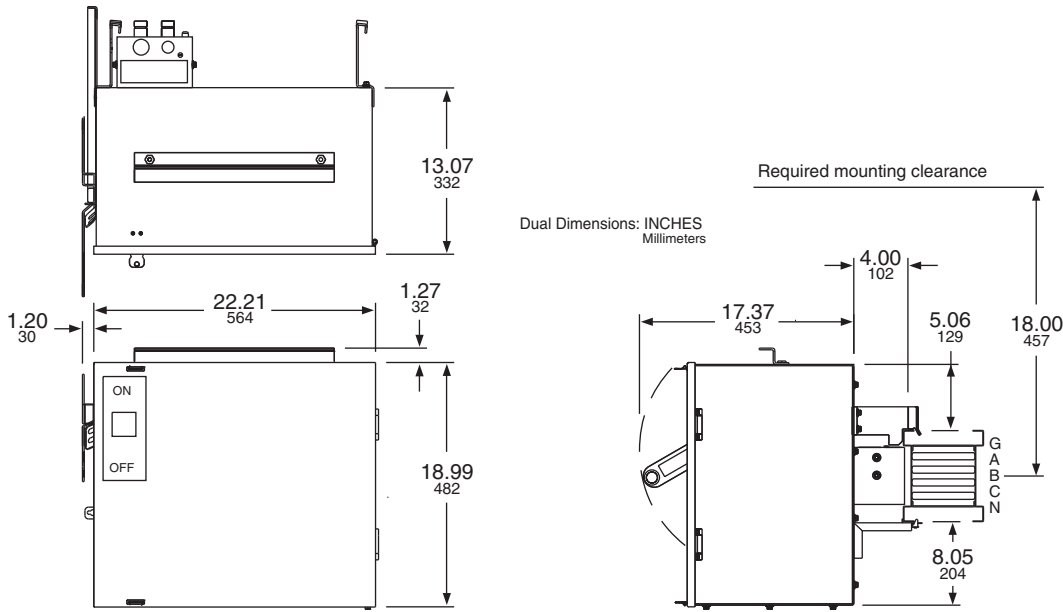

**Fusible Switch Plug-In Unit— 400 A (Type “PBQA”) Specifications**

Fusible Switch		Weight (Approx.)		Lugs Per Phase and Neutral		Ground Lugs	
Cat. No. Prefix	Ampere Rating	Lb	Kg	Qty.	Size	Qty.	Size
PBQA <sup>1</sup>	400	118	53.5	1	#1-600 kcmil	1	#6-300

<sup>1</sup> PBQA units for use on horizontally-mounted busway only.

**NOTE:** Lugs are mechanical type.